

# Taps x-tap



**M** **ISO 2 (6H)**

**HSS PM/F**

**DIN 371/376**

**Form B**

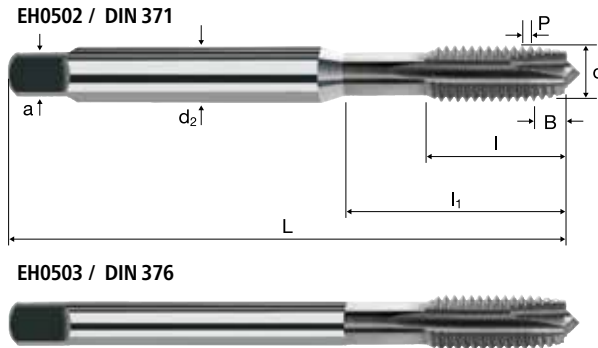

**ToolSchool** EC10540 / EC10541

M

**Rm** < 850    **Rm** 850-1100    **Rm** 1100-1300

Example: Order-N°.		Article-N°.		a-Code							TiCN
		<b>EH0502</b>		<b>034</b>							<b>EH0502</b>
Ø Code	d	P	L	l	l <sub>1</sub>	d <sub>2</sub>	a				
034	M 2	0.40	45	8.00	-	2.8	2.1	2	1.60		●
040	M 2.5	0.45	50	9.00	-	2.8	2.1	2	2.05		●
044	M 3	0.50	56	12.00	18.0	3.5	2.7	3	2.50		●
058	M 4	0.70	63	13.00	21.0	4.5	3.4	3	3.30		●
084	M 5	0.80	70	15.00	25.0	6.0	4.9	3	4.20		●
088	M 6	1.00	80	17.00	30.0	6.0	4.9	3	5.00		●
160	M 8	1.25	90	20.00	35.0	8.0	6.2	3	6.80		●
174	M 10	1.50	100	22.00	39.0	10.0	8.0	3	8.50		●

Example: Order-N°.		Article-N°.		a-Code							TiCN
		<b>EH0503</b>		<b>240</b>							<b>EH0503</b>
Ø Code	d	P	L	l	l <sub>1</sub>	d <sub>2</sub>	a				
240	M 12	1.75	110	24.00	40.0	9.0	7.0	3	10.20		●
244	M 14	2.00	110	26.00	40.0	11.0	9.0	3	12.00		●
246	M 16	2.00	110	27.00	40.0	12.0	9.0	3	14.00		●
312	M 18	2.50	125	30.00	45.0	14.0	11.0	4	15.50		●
314	M 20	2.50	140	32.00	50.0	16.0	12.0	4	17.50		●
316	M 22	2.50	140	32.00	50.0	18.0	14.5	4	19.50		●
320	M 24	3.00	160	34.00	60.0	18.0	14.5	4	21.00		●

## Application

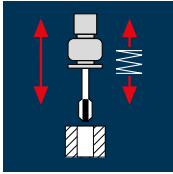

## Material

Steel  
500 - 850 N/mm<sup>2</sup>



Steel  
500 - 850 N/mm<sup>2</sup>



Steel  
850 - 1100 N/mm<sup>2</sup>



Steel  
850 - 1100 N/mm<sup>2</sup>



Steel  
1100 - 1300 N/mm<sup>2</sup>



Steel  
1100 - 1300 N/mm<sup>2</sup>



M	d [mm]	P [mm]	v <sub>c</sub> 1.5 x d			v <sub>c</sub> 2.0 x d			v <sub>c</sub> 3.0 x d		
			n [min <sup>-1</sup> ]	v <sub>f</sub> [100%]	n [min <sup>-1</sup> ]	v <sub>f</sub> [100%]	n [min <sup>-1</sup> ]	v <sub>f</sub> [100%]	n [min <sup>-1</sup> ]	v <sub>f</sub> [100%]	
M2	2.000	0.40	25	3980	1592	20	3185	1274	15	2385	954
M2.5	2.500	0.45	25	3185	1433	20	2545	1145	15	1910	860
M3	3.000	0.50	25	2655	1328	20	2120	1060	15	1590	795
M4	4.000	0.70	25	1990	1393	20	1590	1113	15	1195	837
M5	5.000	0.80	25	1590	1272	20	1275	1020	15	955	764
M6	6.000	1.00	25	1325	1325	20	1060	1060	15	795	795
M8	8.000	1.25	25	995	1244	20	795	994	15	595	744
M10	10.000	1.50	25	795	1193	20	635	953	15	475	713
M12	12.000	1.75	25	665	1164	20	530	928	15	400	700
M14	14.000	2.00	25	570	1140	20	455	910	15	340	680
M16	16.000	2.00	25	495	990	20	400	800	15	300	600
M18	18.000	2.50	25	440	1100	20	355	888	15	265	663
M20	20.000	2.50	25	400	1000	20	320	800	15	240	600
M22	22.000	2.50	25	360	900	20	290	725	15	215	538
M24	24.000	3.00	25	330	990	20	265	795	15	200	600
M2	2.000	0.40	20	3185	1274	15	2385	954	12	1910	764
M2.5	2.500	0.45	20	2545	1145	15	1910	860	12	1530	689
M3	3.000	0.50	20	2120	1060	15	1590	795	12	1275	638
M4	4.000	0.70	20	1590	1113	15	1195	837	12	955	669
M5	5.000	0.80	20	1275	1020	15	955	764	12	765	612
M6	6.000	1.00	20	1060	1060	15	795	795	12	635	635
M8	8.000	1.25	20	795	994	15	595	744	12	475	594
M10	10.000	1.50	20	635	953	15	475	713	12	380	570
M12	12.000	1.75	20	530	928	15	400	700	12	320	560
M14	14.000	2.00	20	455	910	15	340	680	12	275	550
M16	16.000	2.00	20	400	800	15	300	600	12	240	480
M18	18.000	2.50	20	355	888	15	265	663	12	210	525
M20	20.000	2.50	20	320	800	15	240	600	12	190	475
M22	22.000	2.50	20	290	725	15	215	538	12	175	438
M24	24.000	3.00	20	265	795	15	200	600	12	160	480
M2	2.000	0.40	7	1115	446	4	635	254	-	-	-
M2.5	2.500	0.45	7	890	401	4	510	230	-	-	-
M3	3.000	0.50	7	745	373	4	425	213	-	-	-
M4	4.000	0.70	7	555	389	4	320	224	-	-	-
M5	5.000	0.80	7	445	356	4	255	204	-	-	-
M6	6.000	1.00	7	370	370	4	210	210	-	-	-
M8	8.000	1.25	7	280	350	4	160	200	-	-	-
M10	10.000	1.50	7	225	338	4	125	188	-	-	-
M12	12.000	1.75	7	185	324	4	105	184	-	-	-
M14	14.000	2.00	7	160	320	4	90	180	-	-	-
M16	16.000	2.00	7	140	280	4	80	160	-	-	-
M18	18.000	2.50	7	125	313	4	70	175	-	-	-
M20	20.000	2.50	7	110	275	4	65	163	-	-	-
M22	22.000	2.50	7	100	250	4	60	150	-	-	-
M24	24.000	3.00	7	95	285	4	55	165	-	-	-